

RK 500

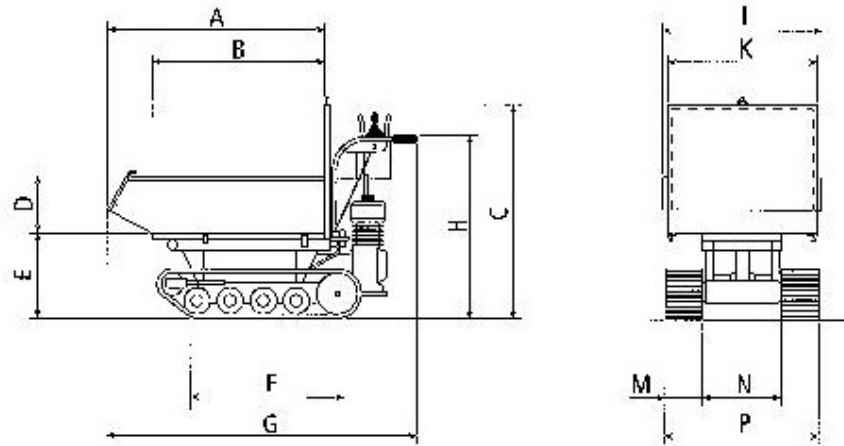

RK 602 RK 700 RK 900

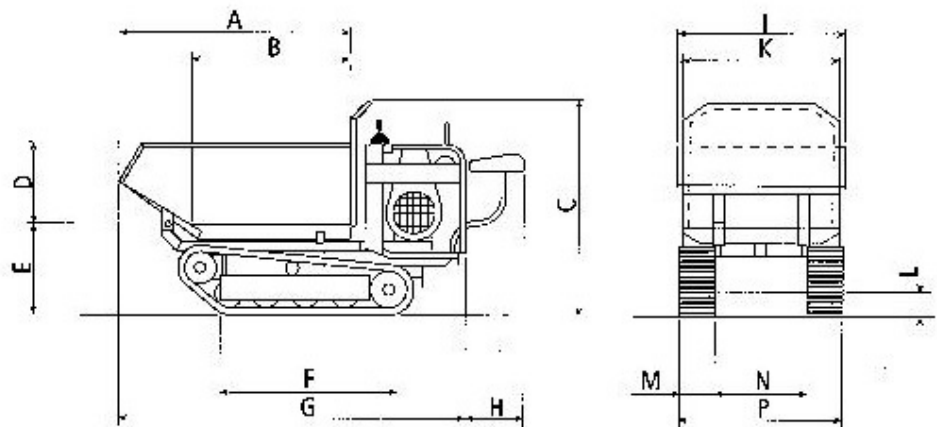

	Nutzlast [kg]	Muldeninhalt [l]	Eigengewicht [kg]	Parkbremse	Motor
RK 500 / 68	500	220	340	mechanisch	Honda, 9 PS
RK 500 / 78	500	220	340	mechanisch	Honda, 9 PS
RK 602	600	300	464	mechanisch	Kubota, 11 PS
RK 700	700	350	520	hydraulisch	Vanguard, 14 PS
RK 900 Benzin	900	450	573	hydraulisch	Vanguard, 18 PS
RK 900 Diesel	900	450	620	hydraulisch	Ruggerini, 17 PS

	A	B	C	D	E	F	G	H	I	K	L	M	N	P
RK 500 / 68	1145	915	1120	290	600	850	1620	950	680	640		180	315	675
RK 500 / 78	1145	915	1120	240	600	850	1620	950	780	740		180	415	775
RK 602	1180	850	1119	350	463	860	1760	370	880	810	145	200	475	875
RK 700	1220	850	1119	420	463	930	1890	280	880	810	145	200	475	875
RK 900	1320	950	1170	420	463	1020	1975	295	980	910	145	200	575	975